

Compensator



discom

EXHAUST TECHNOLOGY

Solutions for a **better world**

Compensators are designed to absorb movements, for example caused by extension. Also compensators are important for reduction of vibration transfer. Vibration reduction is of major importance for optimal functioning of exhaust silencer systems. Discom has a complete program of Stainless steel compensators for exhaust systems. The program comprises two types, fitted with weld ends or rotating flanges, available are sizes from NB 40/80 to NB 500. On request also compensators fitted with welded flanges are available.

Weld end and rotating type flanges are available from stock. Their construction with two layers guarantees a high level of reliability, making them less sensitive to damages. Discom compensators are characterized by their flexibility at low loads and a fully uninterrupted passage, meaning hardly any loss of pressure.

Mounting

The pipe ends must be in line, these compensators are not designed for misalignment correction. Torsion free mounting is also of importance.

Note!

Lateral loads will limit axial movements (see graph).

Quality and safety

Our manufacturing process from design to delivery is in conformity with the ISO 9001:2000 standard, for which we have been certified. Our compensators are built-in components, therefore no CE marking applies. However in the description of your final product you will have to indicate any potential dangers, for example risk of burns.

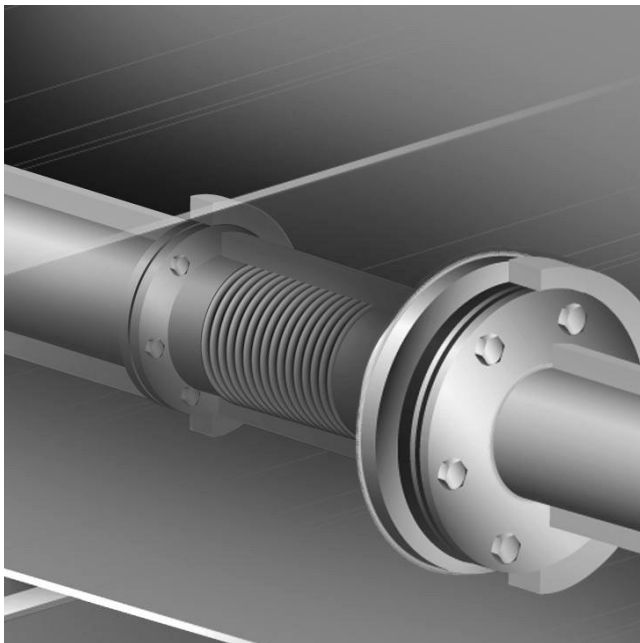

Technical specifications

Material	Bellow	2 layers of Stainless steel 1.4541 (321)
Max. allowable gas temperature	Weld ends/Flanges	S235 JR G2, other materials on request
Design pressure		550°
Flanges		0.5 bar
		Drilled according to DIN 2573 PN 6 standard
		Other flange types on request

Dimensions

Type	A (mm)	B (mm)	C (mm)		D (mm)	E (mm)	Movements (mm)		N / mm		
NB	INCH		- flange	+flange			+/- axial	+/- lateral	C axial	C lateral	
40	1½"	48,3	67,4	205	-	138	2,6	31	26	22	9
50	2"	60,3	81,3	245	-	149	2,9	38	38	19	11
65	2½"	76,1	99,8	245	-	156	2,9	45	27	19	16
80	3"	88,9	114,1	245	255	156	3,2	49	26	19	22
90	3½"	101,6	114,1	245	-	156	3,6	49	26	19	22
100	4"	114,3	142,4	245	255	147	3,6	53	21	19	46
125	5"	139,7	170,5	245	255	147	3,6	56	19	19	69
150	6"	168,3	201,6	245	255	140	4	46	12	45	221
175	7"	193,7	232	245	-	134	4,5	49	11	45	353
200	8"	219,1	262,7	245	255	140	4,5	54	11	45	442
250	10"	273,0	320,6	245	255	157	5	60	10	42	468
300	12"	323,9	373,5	295	305	176	5,6	69	12	39	533
350	14"	355,6	409,2	295	305	189	5,6	75	13	34	491
400	16"	406,4	464	295	305	198	6,3	78	12	32	525
450	18"	457,2	518,6	295	305	193	6,3	77	10	32	711
500	20"	508,0	573,6	295	305	183	6	75	9	34	999

Types 040, 050, 065, 090 and 175 are only available with fitted weld ends

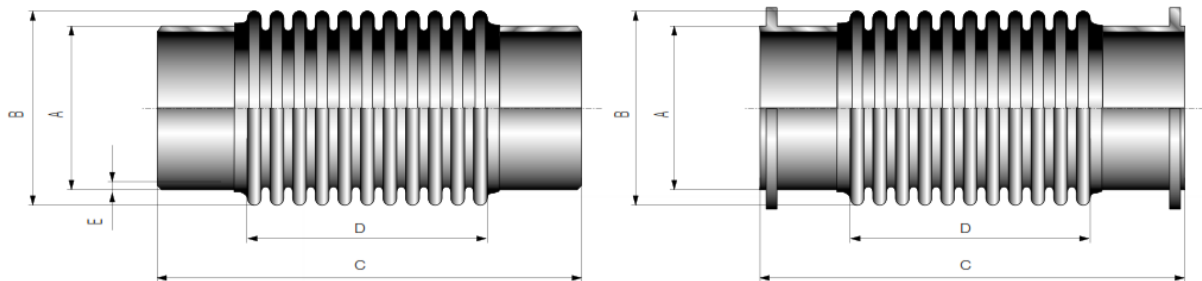

Example for calculation Compensator NB400

Max. compensator movements:
Axial max. +/- 78 mm or
Lateral max. +/- 12 mm

Example

Compensator movements:
Lateral +/- 5 mm resulting
in
+/- 41 mm axial

